



Underground Cable Fault Detection Using IOT

¹M. Sreedhar Reddy,²Vituri Shravya,³Meesa Sreeja,⁴Motkuri Saketh Goud,⁵Eendly Vinesh,

¹Assistant Professor, Department of ECE, Narsimha Reddy Engineering Collage, Maisammaguda(V), Kompally, Telangana.

^{2,3,4,5} Student, Department of ECE, Narsimha Reddy Engineering Collage, Maisammaguda(V), Kompally, Telangana.

Abstract:

Particularly in urban areas with a high concentration of underground cable lines, the accuracy of fault detection has long been an issue; the suggested method aims to address this. The system measures the wire length in kilometers using current measurement circuits coupled to the microcontroller's built-in Analog to Digital Converters (ADC) device. It does this using an Arduino microcontroller kit and a power supply that has been connected. To simulate malfunctions, a relay circuit is used, which in turn controls the switches. In real time, information about the situation are shown on a 16x2 LCD screen. The underground cable might have short circuit problems due to environmental factors such as rain, subterranean pollutants, drain leakage, etc. Locating a short circuit defect is the primary emphasis of this study, however there are many possible flaws in subterranean wire. The ADC digitizes the distance from the source feed point and displays it on the LCD. It senses the position of the short circuit defect as a voltage shift across the resistor. Information about the exact location of the problem is uploaded to the cloud for analytical purposes by means of the Wi-Fi module 82666. Because of this, the anticipated Arduino microcontroller design can pinpoint the precise location of the problem in terms of kilometers from the base station. Field personnel are additionally alerted to the urgency of the situation by a buzzer warning. When it comes to locating and identifying issues with underground cable cables, this innovative approach is dependable and successful. This reduces downtime and makes service simpler. A few key terms for this index are: LCD, Arduino, Internet of Things, cable, fault detection.

I. INTRODUCTION

Having dependable subterranean cable connections is crucial to the efficient operation of civic infrastructure, since they provide essential services such as internet access, phone service, and electricity distribution. However, it is very difficult to locate and identify issues with these underground cables, particularly in densely populated areas where such infrastructure is prevalent. Fixing this issue would ensure repairs are completed on time, cut down on downtime, and boost overall efficiency. Because of their adaptability, embedded systems have emerged as powerful resources for tackling challenging engineering challenges [1]. Improved accuracy and efficiency in identifying and localizing problems in subterranean cable lines is the goal of this research, which employs embedded technology. The proposed system revolves on an Arduino microcontroller kit. This platform is well-known for its adaptability and user-friendliness, making it ideal for creating integrated solutions [2]. Once the power supply is back on, the Arduino microcontroller takes over as the central processing unit responsible for plotting the steps to identify the issue. This system can exactly determine the length of the buried cable in kilometers by attaching circuits that detect current to the microcontroller's built-in ADC unit [3]. As a whole, fault finding techniques benefit greatly from this feature's ability to restrict the region in which defects may be located. The proposed system's use lies in its ability to mimic issues with the subterranean cable lines. The inclusion of problem-causing switches allows the system to immediately detect and identify issues, allowing for the achievement of this aim [4]. The fault detection procedure



may run smoothly because the relay driver simplifies the handling of relays. In order to make sure that individuals are aware of issues straight away and may take action, a 16x2 LCD panel shows them in real time [5]. We diligently monitor and analyze voltage variations across series resistors in the event of a short circuit. These variations are detected by an ADC, which then converts them into precise digital information. In order to pinpoint the source of the problem, this is an essential step [6]. With this data, the specially built Arduino microcontroller can display, in kilometers from the base station, the precise position of the defect, which is helpful for repair personnel [7]. The system also includes safeguards to ensure it reacts and resolves issues promptly in the event that they arise. When workers in the field are in dire need of immediate action, a buzzer alert will sound a clear warning. This careful approach decreases downtime, lessens potential hazards, and makes things safer in general [8]. In terms of finding and fixing defects in subterranean cable systems, the proposed technology represents a huge step forward. Through the use of cutting-edge technologies such as Arduino microprocessor kits and ADC devices, in conjunction with the capabilities of embedded systems, the system offers a reliable, efficient, and cost-effective method for managing urban infrastructure. In order to make cities more resilient, the proposed system can accurately detect and identify issues, which will revolutionize maintenance practices, guarantee the continuous operation of critical services, and transform the way cities are maintained in general. In this part, we laid out all of the essential tools that would be required to construct the suggested fault finding circuit. Section II provides a literature review on several issues with subterranean cables along with suggested solutions for identifying them. In part III, we see the experimental setup and technique that was employed to find the subterranean cable defect. The findings, which are recorded and sent to the cloud, show the position of the defect at different distances in section IV. The work is concluded and expanded upon in Sections V and IV.

II. LITERATURE SURVEY

More and more, embedded systems are being used to address issues in several domains, including defect detection and localization in subterranean cable networks. The goal of improving the speed and accuracy of defect finding procedures has been the focus of much research into various approaches and technology. A method for locating problems with subterranean power lines was developed by Yang et al. [1] using a distributed parameter approach. In order to reduce downtime and increase accuracy, this technology use mathematical models to speculate on the location of faults along the wire. In a similar vein, Zhao et al. [3] improved upon previous GPS moving wave fault finders for power lines by using wavelet analysis to enhance the accuracy of defect diagnosis. Westrom and Larsen [2] developed a fault distance finder for subterranean cable systems, which is an effective instrument for fault detection, and it is documented in the patent literature. A technique for locating faults in multi-end-aged underground cable systems was shown by Gilany et al. [4] using traveling waves. Our knowledge of how to detect problems in intricate cable networks was greatly enhanced by this. Improving fault detection technologies has been the focus of research by groups like Zhang et al. [9]. They devised a live, incipient fault detection system that uses currents in the sheath at one end of subterranean wires. Unsymmetrical transmission line fault detection was the subject of research by Schulze and Schegner [10]. This furthered our understanding of how to identify problems in power systems. An underground cable inspection device that may be utilized at ground level was designed by Sun et al. [11]. This provides an opportunity to assess the condition of the wires in an unobtrusive manner. Further, a defect detector for subterranean cable networks was developed by Paul and Kakoti [12], which facilitates the detection and correction of such issues. Scientists have also investigated ways to enhance defect detection using emerging technologies such as the Internet of Things (IoT). Looking at the many methods that faults in subterranean cables may be detected, Islam et al. [13] proposed potential directions for the field's growth. Teresa et al. [14] have discussed the potential of Internet of Things (IoT) technology to improve fault monitoring. This highlights the need of fresh perspectives in addressing the evolving challenges associated with subterranean cable management.

Finally, the literature study unveils a plethora of methods and tools aimed at simplifying the detection and repair of



subterranean cable system issues. Scientists are always exploring novel approaches to improve the speed, accuracy, and reliability of defect detection procedures. Among these novel approaches are mathematical models, wavelet analysis, tracking of magnetic fields, and integration of the Internet of Things. With these upgrades, urban infrastructure may become more robust, preventing disruptions to critical services like electricity transmission and communications.

III. METHODOLOGY

A. Proposed Work

As part of the proposed effort, a problem monitoring device for subterranean cable lines will be made using an Arduino microcontroller kit and current measurement circuits. Careful measurement of the cable length and real-

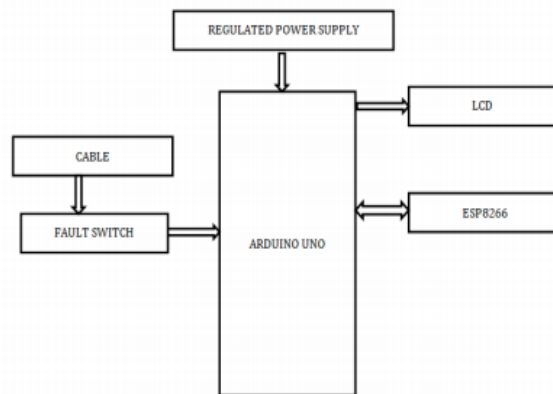

Fig. 1 Block Schematic of Proposed system.

time monitoring of power fluctuations allow for the exact localization and detection of faults. Components of the system include a 16x2 LCD screen for input, a switch driver for issue modeling, and a buzzer for rapid warning. The goal of the system is to provide a reliable and efficient method of locating and fixing issues in underground cable lines using these components, which will decrease downtime and make scheduled maintenance simpler. B. Suggested Plan The proposed block model demonstrates a technique for locating issues with subterranean electricity lines. The device's brains are an ESP8266 module for transmission and an LCD screen linked to an Arduino UNO CPU. A regulated power supply powers the Arduino UNO. To locate problems, an Arduino UNO may be connected to a fault switch, which functions similarly to an underground wire line. The data is processed and displayed on the LCD screen in real time whenever the Arduino UNO detects a defect. You can also interact wirelessly with the ESP8266 module, allowing you to remotely monitor and control items. Finding and fixing issues with underground cable lines is now simpler with an all-in-one solution, which speeds up the process and improves the likelihood of timely repair.

C. Components Used:

- 1) An Arduino UNO: This microcontroller communicates with an LCD panel, an ESP8266 module, and an issue switch to mimic an underground cable line. It is easy to locate problems and see issue data in real time since it obtains its power from a regulated source. Locating issues with subterranean electrical cables is made easier with this compact equipment.
2. ESP8266: The issue monitoring system is able to communicate with other devices



wirelessly thanks to the ESP8266. It facilitates remote monitoring and repair of subterranean wires when coupled with Arduino UNO. Thanks to its compact design and practical characteristics, the ESP8266 enhances the system's data transmission capabilities, facilitating the prompt resolution of issues. 3) LCD: The defect monitoring equipment receives real-time information via the LCD panel. When linked to the Arduino UNO, it displays issue data in a simple and understandable way, making it easier for users to use and comprehend. Faults in subterranean cables may be swiftly located and repaired thanks to the LCD's easy-to-read and comprehend 16x2 display design. Four, the Fault Monitoring System's Fault Switch Pretends That There Are Issues With The Underground Cable Line. It triggers test and confirm conditions when linked to the Arduino UNO. To simulate various failure scenarios, users may simply flick a switch. Because of this, the system is able to detect and localize issues with the subterranean cable network accurately [15]. The fifth component is the battery, which allows the issue monitoring system to function successfully even in remote areas or those without access to the power grid. When linked to the system, it provides continuous power to components such as the LCD display, ESP8266 module, and Arduino UNO. Because the battery can be charged repeatedly and has a modest size, the device is more transportable and versatile, enabling issue detection in different environments without connecting to external power sources. 6). ADOPTOR: The defect detection system is powered by this portion, which connects to power supply and provides power to components such as the Arduino UNO, ESP8266 module, and LCD display. Electronic devices need DC power, which the converter converts from the alternating current (AC) electricity that comes from wall outlets. This guarantees that the system will always function properly. It is a crucial component of the fault monitoring system because to its standard plug-and-play architecture, which facilitates setup and enhances interoperability.

D. Working Process:

In cities, where underground drains leak and people dig often, the cables running under the earth are particularly vulnerable to environmental factors including temperature swings, moisture, and physical damage [16]. In some

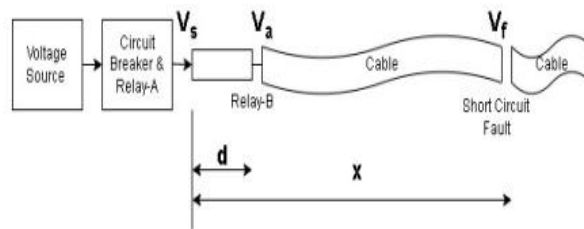

Fig. 2 Short Circuit fault distance measurement.

$$V_s = V_f + xr(Is) + xl \frac{dIs}{dt} \tag{1}$$

cases, strong current may cause temperature to increase, which in turn can detect even the tiniest cable breaks or cuts [17]. Short circuit faults are among the most common types of defects. Figure 2 shows the new method for detecting subterranean cable short circuit faults. In order to pinpoint the exact site of the cable problem, the voltage source supplies V_s to the circuit breaker and relay-A block. A predetermined distance 'd' is used to locate Relay-B. With the known distance 'd' as a starting point, the proposal seeks to estimate the unknown distance 'x' of the fault position from the source feed. To get the unknown distance, use equations 1–3. At the same distance, the cable provides inductance (l) and resistance (r). The potential drop across different places in the cable is given by Equation (1).



In this case, the current supplied by the voltage source is denoted by I_s , and V_f represents the voltage at the site of the short circuit fault. Assuming a dispersed network, the impedance ratio for long-distance cables is equal to the distance ratio, as shown in "(2)".

$$\frac{Z_x}{Z_d} = \frac{R_x}{R_d} = \frac{x}{d} \quad (2)$$

Representing resistances as voltages and currents yields the notation "(3)".

$$\frac{x}{d} = \frac{I_s(V_s - V_f)}{I_s(V_s - V_a)} \quad (3)$$

In the event of a cable short circuit, the V_f is zero and the impedance changes to resistance; hence,

$$x = \left[\frac{V_s}{V_s - V_a} \right] d \quad (4)$$

With the use of the known distance 'd,' the unknown distance 'x' may be determined in "(4)". The proposed method of fault detection in subterranean wires begins with several components being connected to the Arduino UNO. The Arduino can accurately measure the wire length and detect faults with the help of the ADC and current sensing circuits. The fault switch alerts the relay motor, which controls the relays, whenever it detects an issue. The ESP8266 module enables wireless communication, allowing for remote control and monitoring of the device. The ADC converts voltage fluctuations into digital data in the event of a short circuit. From the base station, the Arduino utilizes this information to pinpoint the precise location of the defect, providing correct information to the field personnel. A buzzer alert helps employees know when anything is wrong with the system, allowing them to rectify it immediately. Due to its ability to be supplied by either a regulated power source or a battery, the system is dependable in both urban and rural settings. This reduces downtime in subterranean cable networks and makes maintenance simpler.

Figure 3 is a flow diagram showing the algorithm's operating process. It initializes the modules linked to the Arduino board, detects short circuit problems with location, displays the information on an LCD, alerts the appropriate authorities, and uploads the data to the cloud.

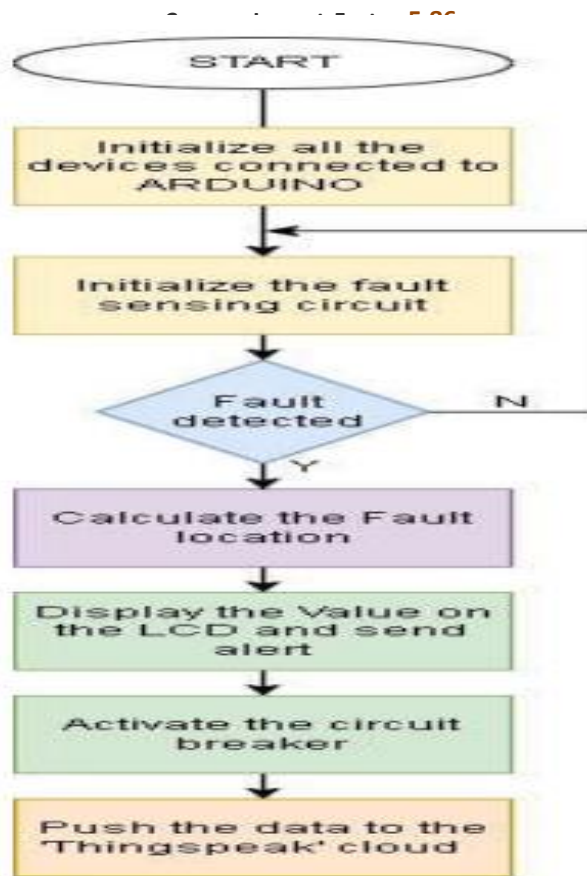

Fig. 3 Operational Flow chart

To accommodate the requirements of the densely populated areas, huge underground cable networks are constructed in major cities. At that point, it is necessary to distribute the Internet of Things technology in order to conduct edge computing in order to identify the problems with the set of cables. Therefore, in these kinds of situations, big edge computing devices are necessary. Having complete monitoring of city-wide defects requires not only the integration of cables, but also the integration of edge computing equipment. It is advised that computer equipment located at the edge be integrated with a central controller or cloud computing device. Below in fig 4 you can see the whole integration configuration.

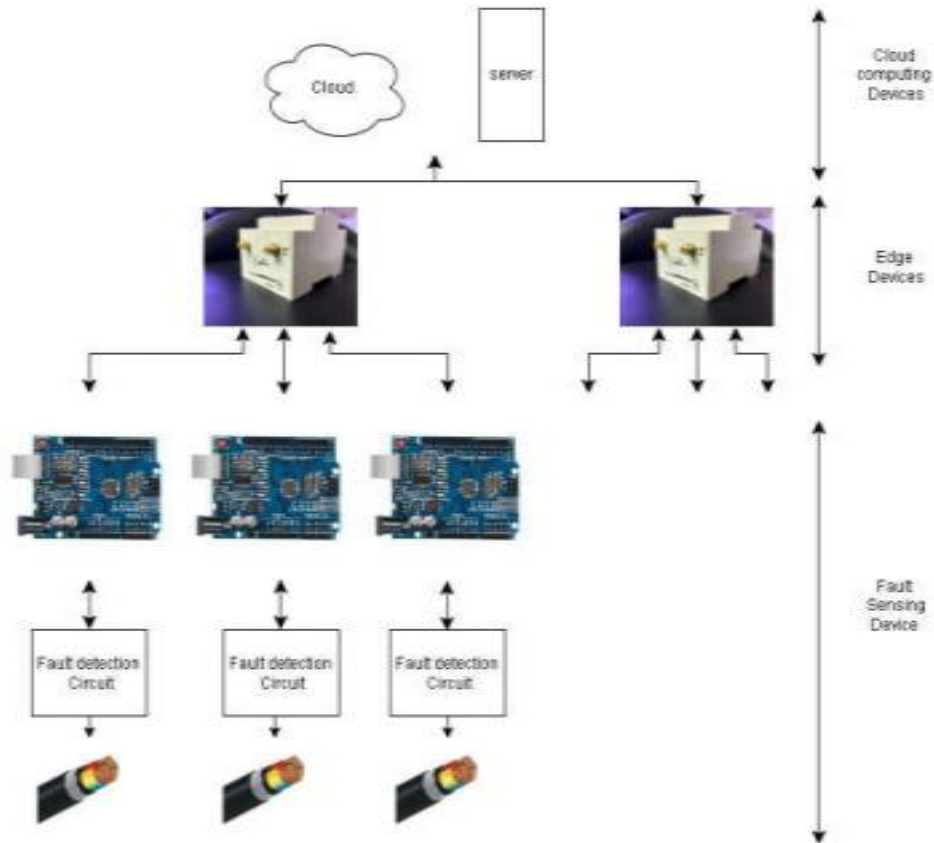

Fig. 4 Integrating cable Fault boards together.

IV. EXPERIMENTAL RESULTS

In order to evaluate the simulated defects, the experimental setup shown in Figure 5 is used. After turning on the setup, the "Welcome note" (Fig.6) will be presented on the LCD screen. A separate resistive network is used to induce the fault. The display displays NF (No Fault) when no fault is formed, and the R on it denotes Resistive fault, as illustrated in Fig.7.

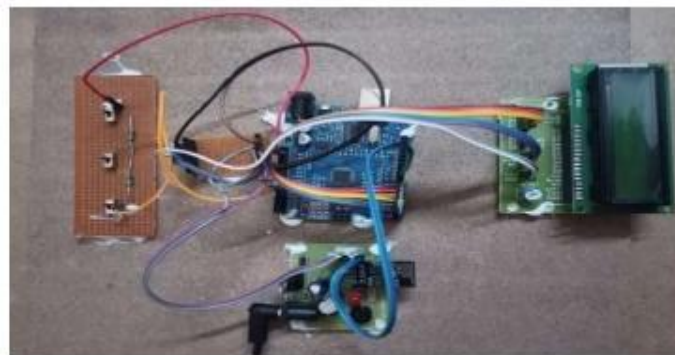

Fig. 5 Equipments & Wire Connection

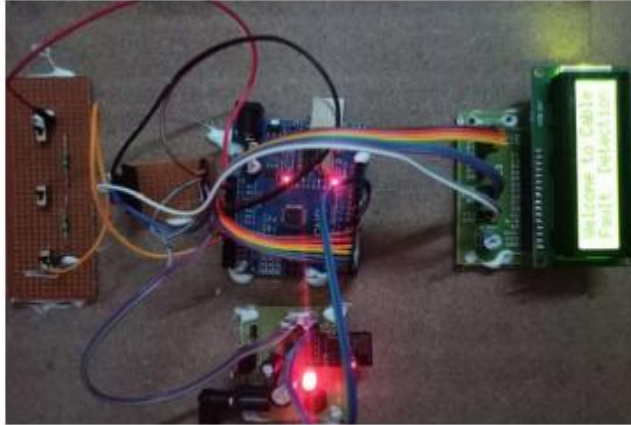

Fig. 6 Equipments & Wire Connection with Welcome Note on LCD



Fig. 7 No Fault Indication



Fig. 8 Fault Indication at 9Km distance

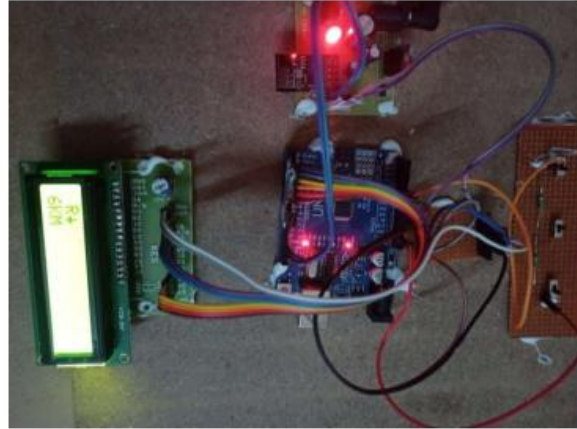

Fig. 9 Fault Indication at 6Km distance

Images 6 and 7 show the readings of resistive faults at 9 and 6 kilometers, respectively, from the test setup.

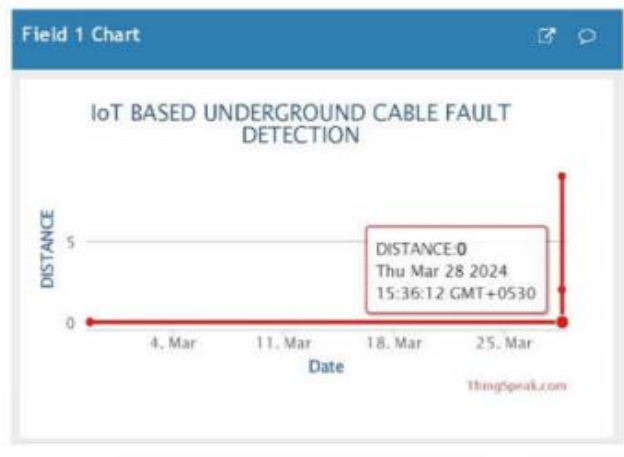

Fig. 10 No Fault.

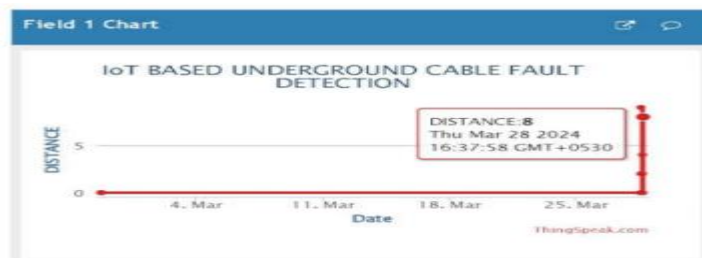

Fig. 11 Fault at distance of 8Kms.

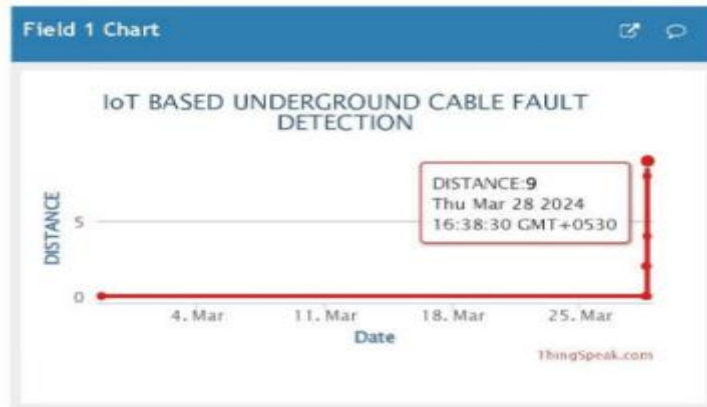

Fig. 12 Fault at distance of 9Kms.

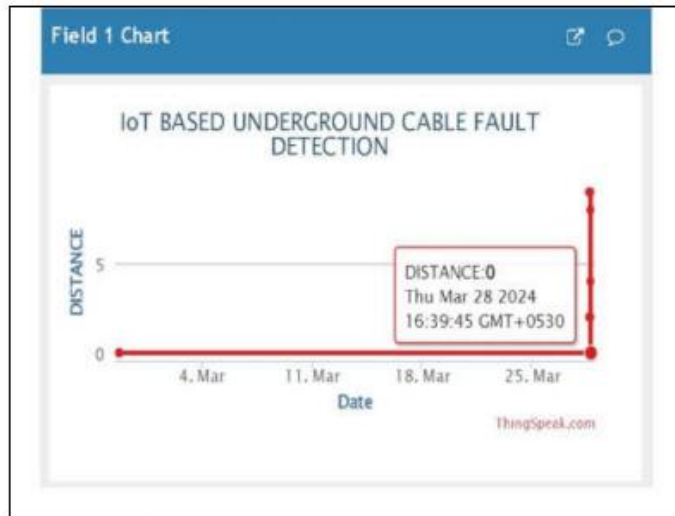

Fig. 13 No Fault.



Data submitted by end devices may be stored, visualized, and analyzed on the Thingspeak.com platform. The data visualization of the short circuit failures at different distances and times on the Thingspeak.com platform is shown in Figures 10–13. We upload the experimental setup's fault location distance calculation to the cloud platform at Thingspeak.com. As shown in Figures 10 and 13, there is no problem on the LCD panel, which reads 0Kms. Figures 11 and 12 illustrate the recorded and visualized fault on the cloud at 8 Kilometers and 9 Kilometers distances, respectively. By combining many of these devices, the relevant authorities may guarantee that the end consumers of the subterranean cable would get better service. Customers who have subscribed may access the data using the newly developed publisher-subscriber model.

V. CONCLUSION

Locating issues with subterranean cable systems is made easy with the help of an Internet of Things–based fault monitoring device. Thanks to built-in components like the ESP32 microcontroller and its Wi-Fi connection, the system can monitor objects in real-time and share issue data online. A voltage divider network is used to determine the unknown distance using the known distance. This streamlines the process of identifying problems and carrying out maintenance. In order to repair the issue or replace the cable, the system can accurately pinpoint its location and communicate this information to the appropriate authorities. This facilitates faster repairs and makes debugging simpler. Date and time tracking capabilities aid in capturing and evaluating issues and make the repair process more responsible and traceable. The device also keeps track of data pertaining to the cable's quality, since all of that data is transferred to the cloud for simple examination. Protecting and studying the cable's statistical behavior over time is possible using switch gears. In general, the underground fault detector system that relies on the internet of things is a significant improvement over previous methods. Modern infrastructure management relies on it because of its capacity to increase overall stability, decrease downtime, and accelerate repair operations.

REFERENCES

- [1] Mansingh, RK Raghul, et al. "Underground Cable Fault Detection using Raspberry Pi and Arduino." *International Journal of Emerging Technologies in Engineering Research (IJETER)* 5.4 (2017).
- [2] Hukeri, Ms Pradnya A., and M. P. Ghewari. "Review paper on iot based technology." *International Research Journal of Engineering and Technology* 4.01 (2017): 23.
- [3] Bascom, E. C., D. W. Von Dollen, and H. W. Ng. "Computerized underground cable fault location expertise." *Proceedings of IEEE/PES Transmission and Distribution Conference*. IEEE, 1994.
- [4] Salat, Robert, and Stanislaw Osowski. "Accurate fault location in the power transmission line using support vector machine approach." *IEEE Transactions on power systems* 19.2 (2004): 979-986.
- [5] Salat, Robert, and Stanislaw Osowski. "Accurate fault location in the power transmission line using support vector machine approach." *IEEE Transactions on power systems* 19.2 (2004): 979-986.
- [6] Islam, Md Fakhurul, Amanullah MT Oo, and Salahuddin A. Azad. "Locating underground cable faults: A review and guideline for new development." *2012 22nd Australasian Universities Power Engineering Conference (AUPEC)*. IEEE, 2012.
- [7] Badillo, M. Fonseca, et al. "Simulation and analysis of underground power cable faults." *International Meeting of Electrical Engineering Research*, Ensenada, Mexico. 2012.
- [8] Pandey, Abishek. "Nicolas H. Younan Underground cable fault detection and identification using Fourier analysis." *2010 IEEE Conference*.
- [9] Zhang, Chao, et al. "On-line incipient faults detection in underground cables based on single-end sheath currents." *2016 IEEE PES Asia-Pacific Power and Energy Engineering Conference (APPEEC)*. IEEE, 2016.
- [10] Schulze, Roberto, and Peter Schegner. "Two-terminal fault location on unsymmetrical transmission lines." *IEEE PES General Meeting*. IEEE, 2010.



- [11] Sun, Xu, et al. "Underground power cable detection and inspection technology based on magnetic field sensing at ground surface level." IEEE transactions on magnetics 50.7(2014): 1-5.
- [12] Paul, Manish, and Raj Kamal Kakoti. "Underground cable fault locator." IARJSET 3.9 (2016): 79-81.
- [13] Islam, Md Fakhrul, Amanullah MT Oo, and Salahuddin A. Azad. "Locating underground cable faults: A review and guideline for new development." 2012 22nd Australasian Universities Power Engineering Conference (AUPEC). IEEE, 2012.
- [14] Teresa, V. V., et al. "IoT-based Underground Cable Fault Detection." 2022 International Conference on Augmented Intelligence and Sustainable Systems (ICAISS). IEEE, 2022.
- [15] Zhao, W., Y. H. Song, and W. R. Chen. "Improved GPS travelling wave fault locator for power cables by using wavelet analysis." International journal of electrical power & energy systems 23.5 (2001): 403-411.
- [16] Gilany, Mahmoud, and Doaa khalil Ibrahim. "Traveling-wavebased fault-location scheme for multiend-aged underground cable system." IEEE Transactions on power delivery 22.1 (2006): 82-89.
- [17] Yang, Xia, et al. "Fault location for underground power cable using distributed parameter approach." IEEE Transactions on Power Systems 23.4 (2008): 1809-1816.